

RC6302

Dual Video Amplifier

Features

- Unity gain stable
- 70 MHz -3 dB Bandwidth
- 20 MHz ± 0.1 dB gain flatness
- 0.06% differential gain ($R_L = 150\Omega$)
- 0.06° differential phase ($R_L = 150\Omega$)
- High CMRR (100dB), High PSRR (80 dB)
- Dual $\pm 5V$ power supply
- Low offset 1.0 mV
- 8-pin narrow SO package
- 160 V/ μs slew rate
- Fast settling time: 0.1% in 35 ns

Description

The RC6302 consists of two low power, wide band voltage feedback operational amplifiers. Each channel is capable of delivering a load current of at least 35mA. The amplifiers are optimized for video applications where low differential gain and low phase distortion are significant requirements.

Applications

- Video amplifier
- Video instrumentation amplifier
- Active filter

Block Diagram

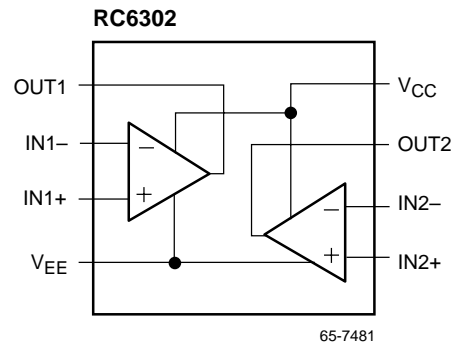

Pin Assignments

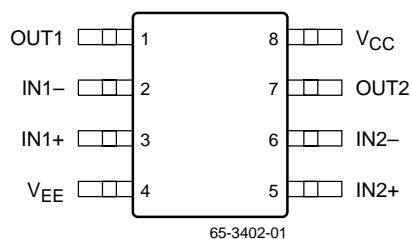

Pin Definitions

Pin Name	Pin Number	Pin Function Description
IN1-	2	Amplifier 1 inverting input
IN1+	3	Amplifier 1 non-inverting input
IN2-	6	Amplifier 2 inverting input
IN2+	5	Amplifier 2 non-inverting input
OUT1	1	Amplifier 1 output
OUT2	7	Amplifier 2 output
VEE	4	Negative supply voltage
VCC	8	Positive supply voltage

Absolute Maximum Ratings

(beyond which the device may be damaged)¹

Parameter	Min	Typ	Max	Units
Positive power supply, VCC			7	V
Negative power supply, VEE			-7	V
Differential input voltage			10	V
Operating Temperature	0		+70	°C
Storage Temperature	-40		+125	°C
Junction Temperature			150	°C
Lead Soldering Temperature (10 seconds)			300	°C
Operating Temperature	0		+70	°C
Short circuit tolerance: No more than one output can be shorted to ground.				

Note:

- Functional operation under any of these conditions is NOT implied. Performance and reliability are guaranteed only if Operating Conditions are not exceeded.

Operating Conditions

Parameter	Min	Typ	Max	Units	
VCC	Power Supply Voltage	4.75	5.0	5.25	V
VEE	Negative Supply Voltage	-4.75	-5.0	-5.25	V
θ_{JA}	SO8 Thermal Resistance		140		°C/W

DC Electrical Characteristics

$V_{CC} = 5V$, $V_{EE} = -5V$, $A_V = 2$, $T_A = 0^{\circ}C$ to $70^{\circ}C$, $R_{LOAD} = 150\Omega$, unless otherwise specified.

Parameter		Conditions	Min	Typ	Max	Units
VOS	Input Offset Voltage	No load		1.0	±5	mV
$\Delta V_{OS}/\Delta T$	Offset Voltage Drift ¹			6.0	±50	$\mu V/^{\circ}C$
I _B	Input Bias Current			±1.0	±5	μA
$\Delta I_B/\Delta T$	Input Bias Current Drift ¹			±8.0	±50	nA/ $^{\circ}C$
R _{IN}	Input Resistance ¹		1			M Ω
C _{IN}	Input Capacitance ¹			0.5	2	pF
CMIR	Common Mode Input Range		±2.5			V
CMRR	Common Mode Rejection Ratio	No Load	70	100		dB
PSRR	Power Supply Rejection Ratio	No Load	60	80		dB
I _s	Quiescent Supply Current	No Load, Whole IC		15	25	mA
R _{OUT}	Output Impedance ¹	At DC		0.2		Ω
I _{OUT}	Output Current			35		mA
V _{OUT}	Output Voltage Swing	No Load	±2.5	±3.0		V
		RL=150 Ω	±2.5	±3.0		V
AVOL	Open-loop Gain		58	68		dB

Note:

1. Guaranteed by design.

AC Electrical Characteristics

$V_{CC} = 5V$, $V_{EE} = -5V$, $R_{LOAD} = 150\Omega$, $R_G = R_F = 250\Omega$, $A_V = 2$, $T_A = 0$ to $70^\circ C$, $C_L = 10$ pF, $C_F = 3$ pF unless otherwise specified. Closed Loop. See Typical Test Circuit.

Parameter	Conditions	Min	Typ	Max	Units	
Frequency Response						
BW	-3 dB Bandwidth ($A_V = 2$) ¹	$V_{OUT} = 0.4$ Vpp		70	MHz	
		$V_{OUT} = 0.8$ Vpp		55	MHz	
Flat	± 0.1 dB Bandwidth ¹	15	20		MHz	
Peak	Maximum Small Signal AC Peaking		0.3		DB	
XTALK	Crosstalk Isolation ¹	@ 5 MHz	60		dB	
Time Domain Response						
t_{r1} , t_{f1}	Rise and Fall Time 10% to 90% ¹	2V Output Step		6	8	ns
t_s	Settling Time to 0.1 % ¹	2V Output Step		35		ns
OS	Overshoot ¹	2V Output Step		13		%
US	Undershoot ¹	2V Output Step		4		%
SR	Slew Rate ¹	$V_{OUT} = \pm 2.0V$		160		V/ μs
Distortion						
HD2	2nd Harmonic Dist. @ 20 MHz ¹	$V_{OUT} = 0.8$ Vpp		-50		dB
HD3	3rd Harmonic Dist. @ 20 MHz ¹	$V_{OUT} = 0.8$ Vpp		-50		dB
Equivalent Input Noise						
NF	Noise Floor > 100 KHz ¹			-140		dBm
SND	Spectral Noise Density ¹	100 kHz to 200 MHz		10		nV/ \sqrt{Hz}
Video Performance						
DG	Diff. Gain (p-p), NTSC & PAL ¹	$R_L = 150\Omega$, $V_{OUT} = \pm 1.5V$		0.06		%
DP	Diff. Phase (p-p), NTSC & PAL ¹	$R_L = 150\Omega$, $V_{OUT} = \pm 1.5V$		0.06		Deg.

Note:

1. Guaranteed by design.

Applications Discussion

Capacitive Load

The RC6302 can drive a capacitive load from 10 to over 100 pF. In back terminated video applications, bandwidth will only be limited by the RC time constants of the external output components. A minimum 10 pF capacitive load is required. When driving a 75Ω cable, place the 75Ω source termination resistor as close to the amplifier output as possible.

DC Accuracy

Since the RC6302 is a voltage-feedback amplifier, the inverting and non-inverting inputs have similar impedances and bias currents. To minimize offset voltage, match the source resistances seen by inverting and non-inverting inputs.

Feedback Components

Because the RC6302 is a voltage-feedback amplifier, it facilitates using reactive (capacitive and inductive) feedback components for implementing filters, integrators, sample/hold circuits, etc. The feedback network and the parasitic capacitance at the inverting (summing junction) input create a pole and affect the transfer function of the circuit. For stable operation, minimize the parasitic capacitance and equivalent resistance of the components used in the feedback circuit.

Circuit Board

High-frequency applications require good grounding, power supply decoupling, low parasitic capacitance and inductance, and good isolation between the three inputs to minimize their crosstalk. Minimal coupling from output to input should exist to prevent positive feedback.

Typical Test Circuit

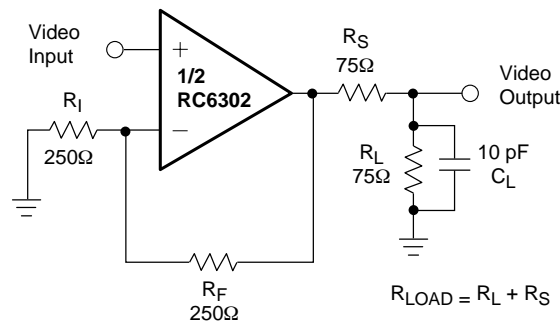

65-7482A

Mechanical Dimensions – 8-Lead SOIC Package

Symbol	Inches		Millimeters		Notes
	Min.	Max.	Min.	Max.	
A	.053	.069	1.35	1.75	
A1	.004	.010	0.10	0.25	
B	.013	.020	0.33	0.51	
C	.008	.010	0.20	0.25	5
D	.189	.197	4.80	5.00	2
E	.150	.158	3.81	4.01	2
e	.050 BSC		1.27 BSC		
H	.228	.244	5.79	6.20	
h	.010	.020	0.25	0.50	
L	.016	.050	0.40	1.27	3
N	8		8		6
α	0°	8°	0°	8°	
ccc	—	.004	—	0.10	

Notes:

1. Dimensioning and tolerancing per ANSI Y14.5M-1982.
2. "D" and "E" do not include mold flash. Mold flash or protrusions shall not exceed .010 inch (0.25mm).
3. "L" is the length of terminal for soldering to a substrate.
4. Terminal numbers are shown for reference only.
5. "C" dimension does not include solder finish thickness.
6. Symbol "N" is the maximum number of terminals.

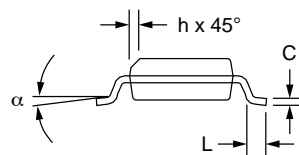
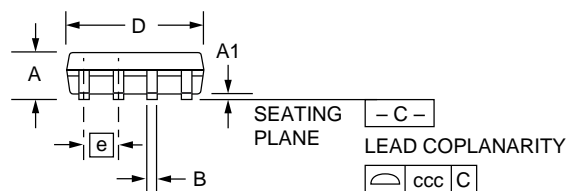
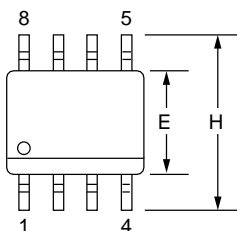

Ordering Information

Product Number	Temperature Range	Screening	Package	Package Marking
RC6302M8	0° to 70°C	Commercial	8 Pin Narrow SOIC	RC6302M8

LIFE SUPPORT POLICY

FAIRCHILD'S PRODUCTS ARE NOT AUTHORIZED FOR USE AS CRITICAL COMPONENTS IN LIFE SUPPORT DEVICES OR SYSTEMS WITHOUT THE EXPRESS WRITTEN APPROVAL OF THE PRESIDENT OF FAIRCHILD SEMICONDUCTOR CORPORATION. As used herein:

1. Life support devices or systems are devices or systems which, (a) are intended for surgical implant into the body, or (b) support or sustain life, and (c) whose failure to perform when properly used in accordance with instructions for use provided in the labeling, can be reasonably expected to result in a significant injury of the user.
2. A critical component in any component of a life support device or system whose failure to perform can be reasonably expected to cause the failure of the life support device or system, or to affect its safety or effectiveness.